

**SEPARATOR (STEAM AND GAS DRYER)**  
**TYPE: SPZ-12 DUO**  
**Tmax: 300°C PN16 DN15-150**  
**(optional PN25 DN15-150 and PN40 DN15-100)**

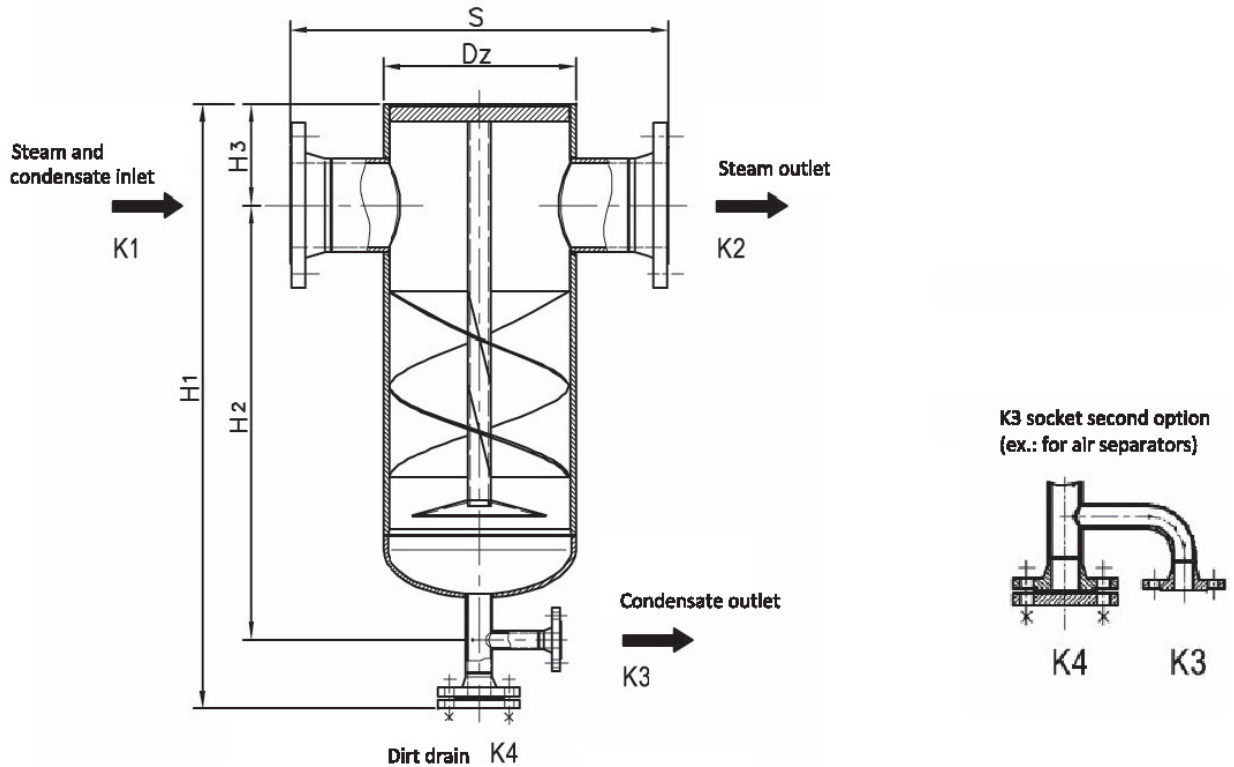

**Main dimensions**

Body		Sockets								Dz	H <sub>1</sub>	H <sub>2</sub>	H <sub>3</sub>	S	PS	TS	V	m
		K1, K2		K3		K4 *		K5 *										
PN	DN	PN	DN	PN	DN	PN	DN	PN	DN	mm	mm	mm	mm	mm	bar	°C	dm <sup>3</sup>	kg
bar	mm	bar	mm	bar	mm	bar	mm	bar	mm									
16	15	16	15	16	15	16	15	16	Rp3/8"	88,9	360	240	50	240	16	300	1,3	6,8
	20		20															7,3
	25		25															7,8
25	15	40	15	40	15	40	15	40	Rp3/8"	88,9	360	240	50	240	25	300	1,3	6,8
	20		20															7,3
	25		25															7,8
25	15	40	15	40	15	40	15	40	Rp3/8"	88,9	360	240	50	240	40	300	1,25	6,8
	20		20															7,3
	25		25															7,8
16	32	16	32	16	15	16	15	16	Rp3/8"	114,3	460	320	70	310	16	300	3,1	12
	40		40															12,5
25	32	40	32	40	15	40	15	40	Rp3/8"	114,3	460	320	70	310	25	300	3,1	12
	40		40															12,5
40	32	40	32	40	15	40	15	40	Rp3/8"	114,3	460	320	70	310	40	300	3,1	12,5
	40		40															13
16	50	16	50	16	15	16	25	16	Rp1/2"	168,3	640	440	100	420	16	300	10,0	26
	65		65															27
	80		80															29
25	50	40	50	40	15	40	25	40	Rp1/2"	168,3	640	440	100	420	25	300	10,0	26
	65		65															28
	80		80															30,5
16	100	16	100	16	20	16	32	16	Rp1/2"	273	900	630	160	560	16	300	38,3	61
	125		125															65
25	100	40	100	40	20	40	32	40	Rp1/2"	273	900	630	160	560	25	300	37,6	75
	125		125															81
16	150	16	150	16	25	16	40	16	Rp1/2"	323,9	1040	735	185	620	16	300	62,2	95

\*Sockets K3, K4 according to the client's request.

## 1. Application range

Maximum operating pressure:	Po max: 1,6 MPa
Test pressure:	PT: 3,6MPa
Maximum operating temperature:	To max: 300°C
Corrosion allowance:	c2=1,0 mm

## 2. Basic materials

Casing/ bottom:	boiler steel
Sockets/ flanges:	carbon steel
Swirl vane :	carbon steel
Optional anticorrosion coating:	zinc plated

## 3. Design

Connections:	flanged DN15 – DN150, face type B1 acc. to PN-EN 1092-1 screwed Rp ½" - Rp 6" at the client's request butt weld ends S ½" – S 6"at the client's request flanges acc. to ANSI or DIN at the client's request K3 socket can be made in two options (see fig. page 26)
--------------	---

## 4. Characteristics

The steam separator is a pressure vessel where condensate is separated from the flowing steam (air). Wet steam (air) together with impurities arrive to the separator via socket "K1" and it changes the direction of the steam flow thanks to a double-spiral swirl vane installed there. Centrifugal force causes the separation of bigger density particles, condensate and solid impurities, which drift onto the separator's walls and then sink to its lowest part. Flowing steam (air) suddenly changes its direction, passing from one spiral into the other one. Steam (air) exits via socket "K2". Separated condensate and impurities sink into the lower part of the separator and are carried away via:

- Socket "K3" on which the most dirt resistant steam trap should be installed. Socket K3 can be pointed sideways or downwards depending on the type of inverted bucket steam trap being used.
- Socket "K4" which is used to carry away impurities. It is bottomed with a blind flange but it can be modified in different ways. It can for example have some additional room for impurities to be collected or a valve to empty accumulating sediment.

Steam separators are used at the entrance of the heat receivers which have to be supplied with good quality steam (dry and without impurities). To trap temporary water swings they can also be installed at the boiler exit just behind its main valve. Air (gas) separators are used at the entrance of the air receivers (vertical apparatus, pneumatic drives, etc.) which also have to be supplied with good quality air. As a matter of servicing personnel safety the outlet flange should be turned on after the pressure in the separator has been reduced to atmospheric pressure. Because of high operating temperatures the separator should be isolated. It should be installed on the pipeline only in the vertical position (socket K4 downward). Medium flow direction for sockets K1 and K2 is optional.

## 5. Requirements and testing

Flanges connecting sizes acc. to PN-EN 1092-1 (DIN; ANSI/ASTM).

Face to face acc. to the table.

Pressure testing acc. to WUDT-UC-WO-B.

Certificate of conformity in acc. with PN-EN 10204.

Design acc. to WUDT-UC-WO-D.

Manufacturing acc. to WUDT-UC-WO-W.

Separators have been submitted for appraisal of conformity according to the Pressure Equipment Directive 97/23/EC.

## 6. Directions for ordering

When giving your order you should supply the following information:

- medium,
- the maximum operating pressure,
- the maximum operating temperature,
- type and size of the connections.

## 7. Additional information

- 24 months warranty compulsory acc. to the conditions which are in the manufacturer's warranty card.
- The manufacturer is able to undertake inspections and repairs of the fittings as well as replacement of the internal elements if required.
- All the requirements concerning the quality and technical specifications of the fittings should be taken into consideration in your order. With the fittings we provide specification sheets (technical and quality) as follows: standard – conformity declaration, Installation, Operation and Maintenance Manual, at the client's request – certificate 2.2 or 3.1.

**We reserve the right to introduce some technical changes without notice.**