

**STOP GLOBE VALVE**  
**TYPE: ZZ218**  
**Tmax: 400 °C PN40 DN15-300**

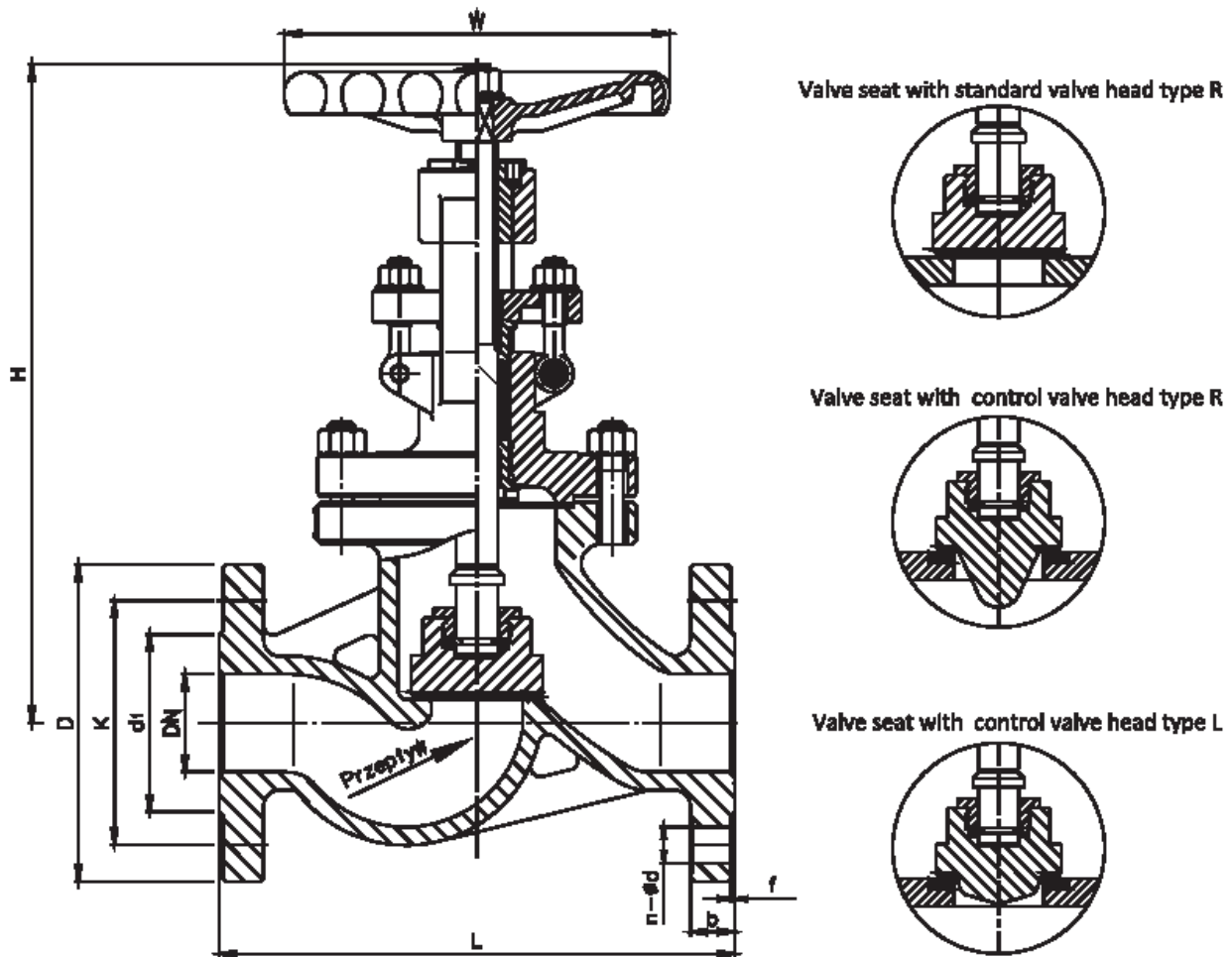

**Main dimensions**

DN	D	K	d1	n-ød	b	f	L (F1)	H (max)	W	Weight
	[mm]									[kg]
15	95	65	45	4-ø14	16	2	130	180	120	3,6
20	105	75	58	4-ø14	18	2	150	190	140	5,1
25	115	85	68	4-ø14	18	2	160	220	160	6,6
32	140	100	78	4-ø18	18	2	180	220	160	8,1
40	150	110	88	4-ø18	18	3	200	255	200	11,7
50	165	125	102	4-ø18	20	3	230	260	240	16
65	185	145	122	8-ø18	22	3	290	265	280	22,6
80	200	160	138	8-ø18	24	3	310	300	320	31
100	235	190	162	8-ø22	24	3	350	310	360	41
125	270	220	188	8-ø26	26	3	400	390	400	60
150	300	250	218	8-ø26	28	3	480	410	450	82
200	375	320	285	12-ø30	34	3	600	495	500	184
250	450	385	345	12-ø33	38	3	730	660	500	285
300	515	450	410	16-ø33	42	4	850	705	500	390

### 1. Application range

Nominal pressure:	PN 4,0 MPa
Body max test pressure:	PT: 6,0 MPa
Seat max test pressure:	PT: 4,4 MPa
Maximum allowable temperature:	TMA: 400°C
Tightness testing pressure (gas test according to PN-EN 12266-1):	PT: 0,6 MPa

DN	PN	Body test pressure PT	Maximum allowable working pressure PMA at related maximum allowable temperature TMA							
			20 °C	100 °C	150 °C	200 °C	250°C	300°C	350°C	400°C
mm	MPa	MPa	Mpa							
15-300	4,0	6,0	4,0	3,73	3,47	3,02	2,84	2,58	2,4	2,31

### 2. Basic materials

Body, bonnet, gland flange:	cast carbon steel GP-240GH (1.0619)
Body seat:	stainless steel X20Cr13 (1.4021)
Valve head:	acid resistant cast steel GX5CrNiMo19-11-2 (1.4408)
Valve head ring:	stainless steel X20Cr13 (1.4021)
Stem, resistance sleeve, gland:	stainless steel X12Cr13 (1.4006)
Gland /stem seal:	Graphite + 1.4301
Bolts/ nuts:	alloy hardened steel A193B7/carbon hardened steel A194 2H
Optional material design:	body made of acid resistant cast steel GX5CrNiMo19-11-2 (1.4408)

### 3. Design

Connection:	flanged DN15 – DN300, face type B1 acc. to PN-EN 1092-1 butt weld ends S ½" – S 14" flanges acc. to ANSI at the client's request
-------------	--

Control valve head type R or L at the client`s request

### 4. Characteristics

Stop valves are used for cutting medium flow (water, steam and other liquid and gaseous neutral mediums at temperatures up to 400°C) on general use pipelines in industrial systems. Stop valves with control head (R or L) can also be used to control the flux of the flowing medium. They can be installed on pipelines in any position but you have to make sure that the medium flow is correct according to the arrow on the valve's body.

### 5. Requirements and testing

Flanges connecting sizes acc. to PN-EN 1092-1.  
Face to face acc. to PN-EN 558-1.  
Pressure testing acc. to PN-EN 12266-1.  
Certificate of conformity in acc. with PN-EN 10204.  
Design acc. to PN-EN 12516-2.  
Valves have been submitted for appraisal of conformity according to the directive Pressure Equipment Directive 97/23/EC.

### 6. Directions for ordering

When giving your order you should supply the following information:

- medium,
- the maximum operating pressure,
- the maximum operating temperature,
- valve head type (standard, control R or L).
- type and size of connections.

### 7. Additional information

- 24 months warranty compulsory acc. to the conditions which are in the manufacturer's warranty card.
- The manufacturer is able to undertake inspections and repairs of the fittings as well as replacement of the internal elements if required.
- All the requirements concerning the quality and technical specifications of the fittings should be taken into consideration in your order. With the fittings we provide specification sheets (technical and quality) as follows: standard – conformity declaration, Installation, Operation and Maintenance Manual, at the client's request – certificate 2.2 or 3.1.

**We reserve the right to introduce some technical changes without notice.**