

WEDGE GATE VALVE WITH RISING STEM
TYPE: ZZK 122SW.425
Tmax: 425 °C PN16 DN40-600

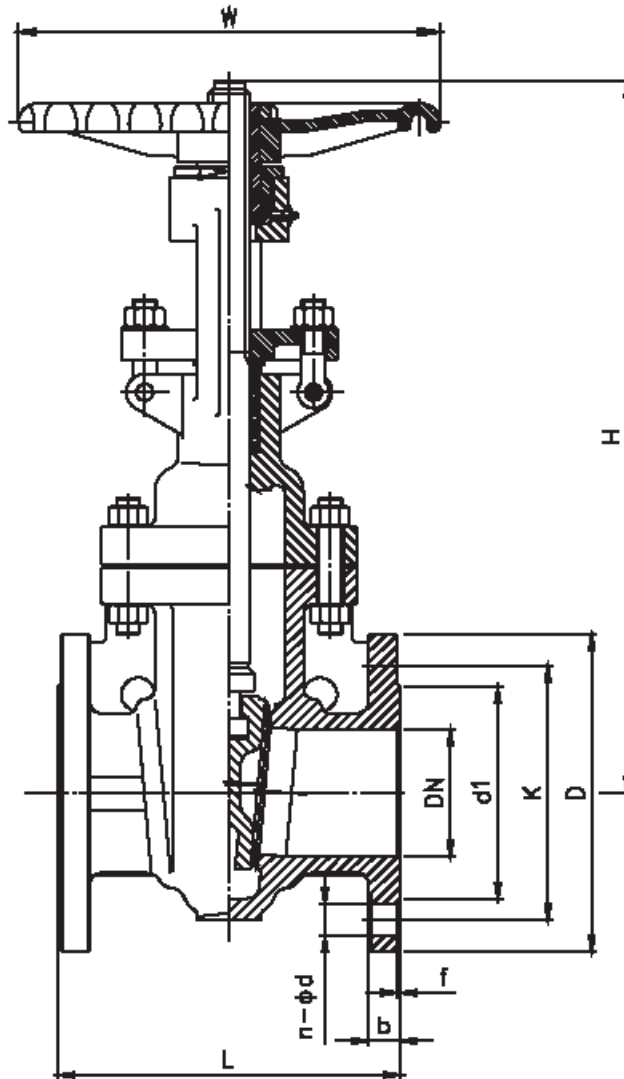

Main dimensions

DN	D	K	d1	n-φd	b	f	L (F4)	H (max)	W	Weight
	[mm]									[kg]
40	150	110	88	4-φ18	18	3	140	296	200	12
50	165	125	102	4-φ18	18	3	150	390	200	15
65	185	145	122	4-φ18	18	3	170	435	200	21
80	200	160	138	8-φ18	20	3	180	515	250	27
100	220	180	158	8-φ18	20	3	190	595	280	32
125	250	210	188	8-φ18	22	3	200	725	300	43
150	285	240	212	8-φ22	22	3	210	780	360	65
200	340	295	268	12-φ22	24	3	230	975	360	88
250	405	355	320	12-φ26	26	3	250	1150	400	125
300	460	410	378	12-φ26	28	4	270	1390	450	155
350	520	470	428	16-φ26	30	4	290	1545	450	225
400	580	525	490	16-φ30	32	4	310	1755	500	320
450	640	585	550	20-φ30	40	4	330	1542	500	508
500	715	650	610	20-φ33	44	4	350	1676	600	600
600	840	770	725	20-φ36	54	5	390	1855	700	780

1. Application range

Nominal pressure:	PN 1,6 MPa
Body max test pressure:	PT: 2,4 MPa
Seat max test pressure:	PT: 1,8 MPa
Maximum allowable temperature:	TMA: 425°C
Tightness testing pressure: (gas test according to PN-EN 12266-1)	PT: 0,6 MPa

DN	Pressure PN	Body test pressure PT	Maximum allowable working pressure PMA at related maximum allowable temperature TMA								
			20 °C	100 °C	150 °C	200°C	250 °C	300°C	350°C	400°C	425°C
mm	MPa	MPa	MPa								
40-600	1,6	2,4	1,6	1,49	1,39	1,24	1,14	1,03	0,96	0,92	0,89

2. Basic materials

Body, bonnet, wedge, gland flange:	cast carbon steel GP-240GH (1.0619)
Body and wedge seat:	cast carbon steel GP-240GH + 13Cr
Stem:	stainless steel X20Cr13 (1.4021)
Gland /stem seal:	graphite + 1.4301
Body and bonnet gasket:	reinforced graphite
Bolts/ nuts:	alloy hardened steel A193 B7/carbon hardened steel A194 2H
Optional material design:	body made of acid resistant cast steel GX5CrNiMo19-11-2 (1.4408)

3. Design

Connection:	flanged DN40 – DN600, face type B1 acc. to PN-EN 1092-1 flanges acc. to ANSI at the client's request
Drive type:	standard version – with a hand-wheel optional version – with an electric drive AUMA or another one indicated by the client
Tightness class:	in standard class C according to PN-EN 12266 -1 for DN40-500, for DN600 class D optional: class A and B with an additional charge

4. Characteristics

Wedge gate valves are designed for general use pipelines in industrial systems, for the second group of fluids. They are designed to cut off the flow of industrial water, drinking water, steam, air. They are also used in chemical industry (for non aggressive and non toxic liquid and gas substances), petrochemical and refinery industries, coke and chemistry industry (coke-oven gas), extractive industry, mining industry, mining and metallurgical industry (post-floatation wastes). They can be installed on pipelines in a vertical or horizontal and operating only when fully open or closed.

5. Requirements and testing

Flanges connecting sizes acc. to PN-EN 1092-1.
Face to face acc. to PN-EN 558-1.
Pressure testing acc. to PN-EN 12266-1.
Certificate of conformity in acc. with PN-EN 10204.
Design acc. to PN-EN 12516-2.
Valves have been submitted for appraisal of conformity according to the directive Pressure Equipment Directive 97/23/EC.

6. Directions for ordering

When giving your order you should supply the following information:

- medium,
- the maximum operating pressure,
- the maximum operating temperature,
- type and size of connections.

7. Additional information

- 24 months warranty compulsory acc. to the conditions which are in the manufacturer's warranty card.
- The manufacturer is able to undertake inspections and repairs of the fittings as well as replacement of the internal elements if required.
- All the requirements concerning the quality and technical specifications of the fittings should be taken into consideration in your order. With the fittings we provide specification sheets (technical and quality) as follows: standard – conformity declaration, Installation, Operation and Maintenance Manual, at the client's request – certificate 2.2 or 3.1.

We reserve the right to introduce some technical changes without notice.